

## Solvent cement welding of ABS

### Basic principle of solvent cement welding

Solvent cement welding is one of the most commonly used jointing techniques for above ground piping. It is a reliable, safe and efficient method of installing ABS piping systems. To make a joint, the outside of the pipe and the inside of the fitting are coated with a chemically active solvent cement, softening and making liquid the surface area to be joined. When joined together the two parts bond almost immediately, and the cement cures to give a joint that is stronger than the pipe itself.

Achieving consistent high quality solvent cement joints requires a systematic approach to the cutting, preparation and assembly of the joint. Most joint failures occur because of dry-joints (lack of solvent cement), however most of the recurring problems can be addressed with training which is available free of charge by contacting our technical department.

To consistently make good joints, the following should be carefully understood:

- The joining surfaces must be softened and made semi-fluid
- Sufficient cement must be applied
- Assembly of the joint must occur while the surfaces are still wet and fluid
- Joint strength develops as the cement dries. In the tight part of the joint the surfaces will tend to fuse together, while in the loose part of the joint the cement will bond to both surfaces.

### Softening and penetration

These are as must be softened and penetrated by the solvent-based cement.

### Sufficient application of cement

It is crucial to apply sufficient cement to fill any gaps and to ensure that the joining surfaces are penetrated so that they remain fluid until the joint is assembled.

### Assembly while wet

If the cement coating on the pipe and fittings is wet and fluid when assembly takes place, they will tend to flow together and become one layer. If the surfaces are soft they will fuse together in the tight part of the joint.

### Developing joint strength

As the solvent dissipates, the cement layer and the softened material will harden with a corresponding increase in joint strength. In the tight (fused) part of the joint the strength will develop more quickly than in the looser (bonded) part of the joint. A good joint will take the required working pressure long before the joint is fully cured and final strength is obtained.

### Health and safety

At all time installers should be aware of good safety practices. Solvent cements, primers and cleaners are flammable, so no smoking or other sources of heat or flame is permitted in the work or storage area. Work only in well ventilated spaces and avoid unnecessary skin contact. Users should read and understand the instructions for use and the material safety data sheets.

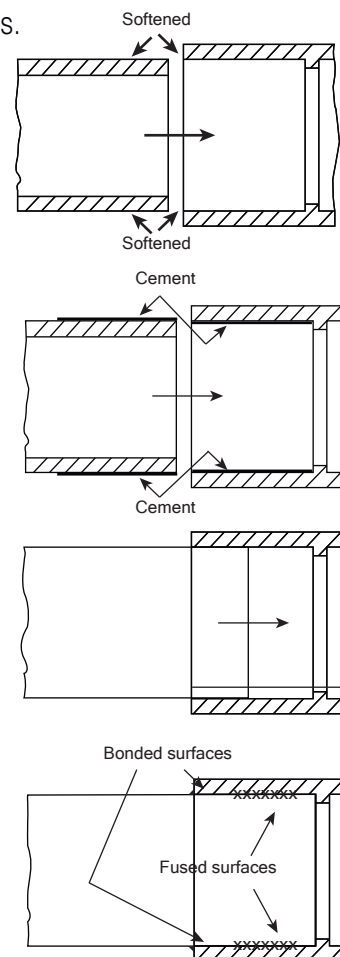

## Solvent cement welding of ABS

### Installers and installation equipment

Installation personnel should be trained and technically competent for this jointing method. Training for installers is available free of charge on request from our technical department.

The tools required for the job should be assembled and checked prior to commencing any work. When assembling longer runs or large size ABS pipes, the use of guides, pipe rollers or supports, is recommended to reduce the drag forces involved.

The work crew should be equipped with equipment to enable safe handling of the pipes on site, together with appropriate hand tools. In addition, it is recommended that the following tools are used during the jointing process. Using tools designed specifically for plastic piping systems greatly improves the performance of the installation team and reduces the risk of bad joints being made.

### Pipe Cutting

Item	Pipe Diameter	Part Number
Rotary Cutter	6 - 63mm	04124
Rotary Cutter	10 - 90mm	04134
Rotary Cutter	48 - 114mm	04144
Rotary Cutter	102 - 168mm	04164
Rotary Cutter	159 - 254mm	04170
Rotary Cutter	160 - 315mm	04470



Saw	Up To 75 mm	04512
Saw	Up To 100mm	04510
Saw	Up To 150mm	04517
Saw	Up To 200mm	04519



### Pipe De-Burring and Beveling

Item	Pipe Diameter	Part Number
Deburring Tool	Up To 2"	04436
Deburring Tool	1/4" To 4"	04430

Beveller	40 - 200mm	04395
Beveller	40 - 300mm	04398



### Large Diameter Joints

Item	Pipe Diameter	Part Number
Pipe Puller	4" - 12"	P0412



### Brushes

Item	Pipe Diameter	Part Number
8mm Round	6 - 25mm	L-151/R
25 x 10mm Flat	32 - 50mm	565/1
50 x 10mm Flat	65 - 125mm	565/2
75 x 10mm Flat	150 - 300mm	565/3



The work crew should also carry the appropriate quantity of solvent cement and cleaner, together with lint-free cloth or wipes, protective eyewear and solvent resistant protective gloves.

## Solvent cement welding of ABS

### Preparation of the work area

Solvent cements and cleaners contain volatile solvents, with fumes that are heavier than air. Good ventilation in the work area is essential to prevent the build up of fumes in enclosed spaces. If fume extraction is to be used, it should be positioned at floor level, or immediately below the working area.

Solvent cements are highly flammable. No naked flames, sparks, heaters or smoking can be permitted in the working area. Also, ensure that any discarded solvent cement containers, brushes, paper or clothes containing traces of solvent cement, cleaner or primer are disposed of safely in sealed containers. Do not pour solvent cements into the drainage system. Clean up any accidental spillage immediately, and prevent pipes and fittings from being contaminated by spills.

The area in which the solvent cement welding is to take place should be clean, dry, and at a temperature greater than 5°C. Solvent cements and primers should be stored in sealed tins. If cements are stored in cold conditions, the temperature must be raised by gradual conditioning in the workplace. The use of protective eyewear, and solvent resistant gloves is required.

Always follow the safety instructions on the can, and the guidance provided with the material safety data sheets that are supplied with each product.

### Pipe cutting and preparation

Before cutting, pipes should be conditioned to reach the ambient working temperature under which installation and jointing will take place.

Pipe should always be cut to length using tools specifically designed for use with plastic pipe. A rotary pipe cutter with the correct blade or wheel appropriate for the pipe wall thickness is recommended, as they provide a high degree of accuracy in the finished cutting length, and also produce a square cut to the pipe. Power tools such as band saws, or circular saws may also be used - however they should have blades that are specifically designed for use with plastic pipe. Handsaws with blades suitable for use with plastic pipe may be used, however it is recommended that a mitre box be used to ensure a square cut is achieved.

The installation of ABS piping systems makes use of so-called "Z" dimension of the fitting. An explanation of the use of the "Z" dimension is shown in the following example:-

Explanation:

M (Distance Mid-Mid Fitting)

L (Cutting Length of Pipe)

Z = Z-dimension of fitting

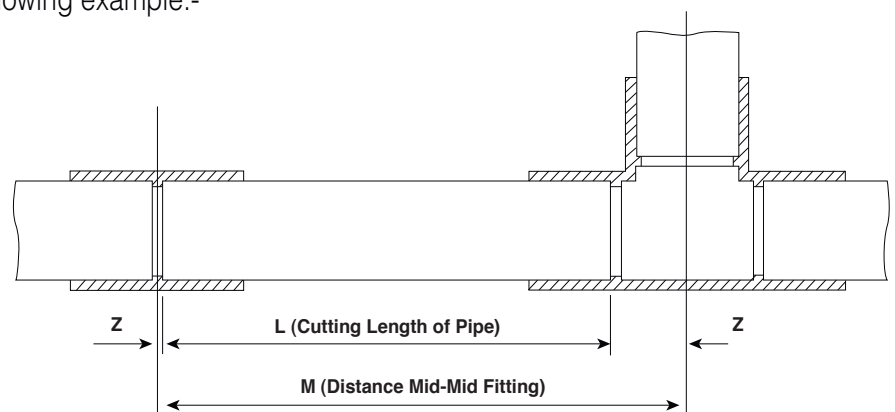

The Z dimension for ABS pipe fittings that is used to calculate pipe cutting lengths can be found in the detailed dimensional information.

Once the cutting process is completed, the pipe length should be checked for accuracy, and any internal or external burrs should be removed using a deburring tool specifically designed for use with plastic pipe. Any plastic chips or swarf should also be removed from the inside of the pipe. The jointing area of the parts to be solvent welded must be free from damage or contamination.

## Solvent cement welding of ABS

### Calculating the required quantity of solvent cement

The following table gives an indication of the number of ABS joints that are likely to be made for each litre of solvent cement, primer and cleaner:

Pipe Diameter		Solvent Cement Joints Per Litre
Inch DN	MM DN	
3/8" - 1"	10 - 25	400
1 1/4" - 2"	40 - 50	200
2 1/2" - 3"	65 - 80	70
4"	100	45
5" - 6"	125 - 150	25
8"	200	15
10" - 12"	250 - 300	4

## Solvent cement welding of ABS

### Making a solvent welded joint - joint preparation

- Bring the pipes, fittings and solvent cements to the same temperature condition. Ensure that the items to be joined are clean and dry prior to use. Inspect the components for any signs of damage or irregularities. Do not use items that appear not to be correct.
- Cut the pipe ends squarely using tool suitable for plastic pipe. A wheel-type cutter is ideal. If a saw is used, a mitre box is recommended to ensure a square cut. Power saws may be used with care.
- Using a chamfering tool cut a 10° to 15° chamfer on the outside of the pipe. This will help ease the pipe into the fitting and minimize the risk of cement being wiped from the fitting during assembly.
- Remove the internal burr from the pipe, and clean up any cutting debris or swarf.
- Measure the insertion depth of the socket and mark it on the pipe end. This makes it possible to verify later that the pipe has completely "bottomed out in the fitting.
- Using clean course emery cloth, thoroughly abrade the end of the pipe over a length equal to the insertion depth of the fitting socket.
- Thoroughly abrade the inside surface of the fitting to be joined.



Chamfering the pipe



Marking the insertion depth on the pipe



Abrading the pipe

## Solvent cement welding of ABS

### Making a solvent welded joint - completing the joint

- Open cans of cleaner, primer and cement ready for use and loosely replace lids to minimise the evaporation of the solvents. Check that the products are in good condition and not "gelled". Cements that are gelled must not be used. Never thin cements.
- If needed, remove dirt with C-65 cleaner applied using a clean, lint-free cloth or paper towel.
- Apply the solvent cement using a natural bristle brush of the correct diameter. The solvent cement coating on the pipe end should be liberally yet evenly applied to a distance equal to the depth of the fitting socket. A medium even coat should be made on the fitting socket surface. For diameters 4" (100mm) and above, or if the fit was loose, a second coat should be applied to the pipe
- **While both surfaces are still wet**, insert the pipe into the fitting until the pipe bottoms out fully in the socket. Check that alignment is correct. Hold the joint to prevent pull out for around 20 to 30 seconds (larger sizes may require more time). A bead of solvent cement should be evident around the pipe and fitting juncture. If the bead is not continuous it may indicate that insufficient solvent cement was applied. If this is the case the joint must be cut out, discarded and begun again with new product. Excess solvent cement should be removed from the mouth of the socket using a clean, dry cloth. Replace lids on cleaner, primer and cement cans to prevent the solvent from evaporating.
- Handle the newly assembled joint with care until the initial set time has elapsed (see set and cure times table). Following the initial set period the assembly can be handled carefully, avoiding stresses on the joint. **All solvent cemented joints must be allowed to cure fully prior to pressure testing.**



Brush applying cement of the fitting



Brush applying cement of the fitting



Assembly

## Solvent cement welding of ABS

### Set and cure times

The initial set between the pipe and the fitting takes place in a matter of minutes, and joints can therefore safely be handled in a very short time. However, the joint needs to cure before it can be used as part of a pressurized assembly. The time taken to achieve this can depend upon a number of factors, including the tightness of fit as well as the ambient temperature and humidity. In general terms, joints will cure faster on tighter fitting assemblies in warmer, drier conditions, whereas looser fit joints made in cooler and/or humid conditions will cure slower.

As a general guide it is recommended that (wherever possible) joints be left for 24 hours to cure before pressure is applied. Sizes 10" and 12" require a minimum of 48 hours. However, where this is not possible, consideration may be given to the above factors before determining when joints are put into service. Given average conditions and a working temperature not exceeding 20°C, a safe guide is to allow a cure time of not less than 1 hour for each bar of working pressure for pipe sizes up to 4" (100mm), and 1fi hours for each bar for larger sizes.

### Large diameter jointing

Solvent cement jointing on pipe sizes 6" (DN 150mm) and larger is a two-person operation. To ensure that primers and solvent cements are applied at the correct speed they should be simultaneously applied to both pipe and fitting. Applying a thorough coating of cement is critical at these sizes both to ensure a good weld and to ease the pipe into the fitting.

For sizes 10" and larger it is recommended to use a ratchet driven pipe puller to ensure that the pipe fully penetrates the fitting. These tools may be hired if required.

### Chemical resistance of solvent welded joints

A well-made solvent cement welded joint will provide excellent chemical resistance characteristics, in the same way as that of the parent piping material.

### Solvent welding of dissimilar materials

As a general guide, solvent welded joints between dissimilar materials are not recommended. Where possible, a mechanical transition joint should be used, such as a union, flange or threaded connection.

If a solvent welded joint is unavoidable, it may (depending upon the conditions) be possible to make a reliable joint provided that a suitable solvent cement is used:

Materials To Be Joined	Recommended Solvent Cement
ABS to PVC-U	Weld-On 719
ABS to PVC-U	Weld-On 724

**Please note that in all cases we recommend contact with our technical department who will be able to provide assistance with specific applications and on recommended jointing methods.**

## Solvent cement welding of ABS

### Making solvent cement welded joints in cold weather

It is sometimes necessary to make solvent cement welded joints in cold temperatures, and this can be successfully achieved even at sub zero temperatures. In cold weather, solvent cements penetrate and soften the plastic surfaces more slowly, and it is therefore more important to use a primer. In addition, the solvent cement will evaporate much more slowly, which means that a longer cure time will be required.

For all practical applications, good solvent cement welded joints can be achieved in very cold conditions by following these guidelines:

- Whenever possible, prefabricate as much of the system in a heated work area
- Store solvent cements and primers in a warmer area when not in use and make sure they remain fluid
- Take special care to remove moisture, ice or snow from the surfaces to be joined
- Use a primer to soften the surface before applying solvent cement. Note more than one application of primer may be required.
- Allow a longer cure period before the system is used. A heat blanket may be used to speed up the set and cure times.
- Read and follow the solvent cement welding instructions before commencing with the installation.

### Making solvent cement welded joints in hot weather

There are occasions when solvent cement welded joints have to be made in hot temperatures, and this can be successfully achieved if special precautions are taken. Solvent cements for thermoplastic piping systems contain high strength solvents that evaporate more quickly at elevated temperatures. If the pipes to join have been stored in direct sunlight, then the pipe surface may be considerably warmer than the ambient temperature. Solvent cements will attack these hot surfaces faster and deeper, especially inside the joint area. Therefore, it is very important to avoid puddling the cement inside the fitting socket and to wipe off any excess cement outside the joint.

For all practical applications, good solvent cement welded joints can be achieved in hot conditions by following these guidelines:

- Store solvent cements and primers in cool or shaded areas before use
- Whenever possible, store fittings and pipe - or at least the ends to be joined - in a shaded area before solvent cementing takes place
- Warm surfaces can be cooled by wiping with a damp cloth. **Be sure that the surface is dry before applying solvent cement**
- Make sure that the surfaces to be joined are still wet with solvent cement when assembling the joint. For larger diameter joints, it may be necessary to increase, the number of personnel required to make the joint.
- Read and follow the solvent cement welding instructions before commencing with the installation.